

Service Manual

PRINTER PRESENTER UNIT
MODEL PPU-700

Rev. 1.00T Newly issued on Jan.15 2007

CITIZEN is a registered trade mark of CITIZEN WATCH CO., LTD., Japan
CITIZEN es una marca registrada de CITIZEN WATCH CO., LTD., Japón

CONTENTS

INTRODUCTION	1
1. FEATURES	1
2. SPECIFICATIONS	2
3. DISASSEMBLY AND REASSEMBLY	3
3.1 Tools Used	3
3.2 Disassembly Procedure	4
3.2.1 Disassembly of Unit	4
3.2.2 Disassembly of Feeder Unit	7
3.2.3 Disassembly of Moving Unit	9
3.2.4 Disassembly of Mechanism.....	11
3.3 Reassembly Procedure	13
3.4 Lubrication	13
4. TROUBLESHOOTING	14
4.1 Troubleshooting Procedure	14
4.2 Troubleshooting Guide	14
5. SERVICE PARTS LIST	19
5.1 Parts List for Mechanism	19
5.2 Exploded View of Mechanism.....	24
5.3 Main Board	29
6. CIRCUIT DIAGRAM	30
6.1 Main Board	30
6.2 Interconnecting Board.....	31
6.3 Serial Interface	32
6.4 Parallel Interface	33
7. EXTERNAL VIEW	34

INTRODUCTION

This manual describes the disassembly, reassembly, and maintenance procedures of the line thermal printer PPU-700.

1. FEATURES

- Paper side-insert mechanism facilitating paper insertion and maintenance.
- Paper width can be chosen among 58, 67, 80, and 82.5 mm.
- Line thermal printing allows high-speed, low-noise printing.
- Allows collection of paper not received. (Paper collection mechanism)
- Small size and light weight requiring minimum installation space.
- High reliability with long-life head and simple mechanism.
- Built-in buffer
- Barcode printing is available with special command.
- Page mode allows free layout of printing.
- User-defined characters and logos can be registered in the flash memory.
- User-defined characters can be registered. (94 Kanji characters, 95 ANK characters)
- Detection of black mark is available. (Option)
- Free layout of units.
- Large-sized roll paper can be used. (Option)
- Built-in buzzer
- Various kinds of customization are available.
- 2-color printing

2. SPECIFICATIONS

Item \ Model	PPU-700-RK PPU-700-PK PPU-700-UK	PPU-700-RU PPU-700-PU PPU-700-UU
Printing method	Line thermal dot print method	
Print width	80 mm/640 dots	
Dot density	8 × 8 dots/mm (203 dpi)	
Print speed	150 mm/s (Fastest, print density level 2), (1200 dot lines/sec)	
Number of print columns	Font A: 48 columns, 12 × 24 dots Font B: 64 columns, 9 × 17 dots Font C: 72 columns, 8 × 16 dots	
	Kanji Font A: 24 columns, 24 × 24 dots Kanji Font B: 36 columns, 16 × 16 dots	
Character size	Font A: 1.50 × 3.00 mm Font B: 1.13 × 2.13 mm Font C: 1.00 × 2.00 mm	
	Kanji Font A: 3.00 × 3.00 mm Kanji Font C: 2.00 × 2.00 mm	
Character type	Alphanumeric characters, International characters, PC850, 852, 857, 858, 860, 863, 865, 866, WPC1252, Katakana	
	Kanji (JIS Level 1, Level 2)	
User memory	256 KB (Capable of registering user-defined characters and logos)	
Barcode type	UPC-A/E, JAN (EAN) 13 columns/8 columns, ITF, CODE 39, CODE 128, CODABAR, CODE 93	
Line spacing	4.23 mm (1/6 in.), selectable by use of command	
Paper (See paper spec.)	Thermal paper roll Width: 58 to 82.5 mm External diameter: φ203 mm max. (when using PHU) Internal diameter: φ25.4 mm Paper thickness: 65 to 150 μm	
Presenter	Minimum length: 90 mm	
Interface	Serial (RS-232C compliant), Parallel (IEEE1284 compliant), USB	
Input buffer	4K bytes/72 bytes	
Supply voltage	DC 24V ±7%	
Power consumption	100 W	
AC adapter specification	Rated input: AC 100V to 240V, 50/60 Hz, 150 VA Rated output: DC 24V, 2A	
	Type	32AD-J 32AD-U 32AD-E
Weight	2.1 kg	
Outside dimensions	163.2 (W) × 176 (D) × 144 (H) mm (See external view)	
Operating temperature and humidity	5 to 40°C, 35 to 85% RH (No dew condensation)	
Storage temperature and humidity	-20 to 60°C, 10 to 90% RH (No dew condensation)	
Reliability	Print head life: 150 km, 100 million pulses (At normal temperature, humidity with recommended paper used)	
	Auto cutter life: 1 million cuts (At normal temperature, humidity, with paper thickness of 0.065 mm)	
Safety Standard *1	VCCI Class A	UL, C-UL, FCC Class A TUV, GS, CE marking

Note:

*1: Represents the safety standards acquired when CBM-made AC adapter (32AD series) is used.

3. DISASSEMBLY AND REASSEMBLY

Notes the following items when maintaining the printer.

- Do not disassemble, reassemble, or adjust the printer unnecessarily when the printer operation is satisfactory.
- Do not loosen the screws fixing each component carelessly.
- After finishing inspection, perform checking for normality before turning on the printer.
- Pay attention not to leave the part or screws used for maintenance inside the printer.
- When handling the print head and electronic components, pay attention to static electricity.
- When disassembling or reassembling the printer, check the wiring and cord for damage. Pay attention not to lay the wiring and cord by force.
- Lubricate the components as necessary when reassembling them.

3.1 Tools Used

- Phillips screwdriver #0, #1, and #2
- Tweezers
- Long-nose pliers
- Oil brush
- Nipper

3.2 Disassembly Procedure

Disassembly procedure is explained in four categories: “Disassembly of Unit”, “Disassembly of Feeder Unit”, “Disassembly of Moving Unit”, and “Disassembly of Mechanism”.

3.3 Reassembly Procedure

Reverse the procedure in “3.2 Disassembly Procedure”.

3.2 Disassembly Procedure

3.2.1 Disassembly of Unit

(1) Removing Control Box

- Remove the three M3×6 (ST) screws and remove the Control Box Cover.

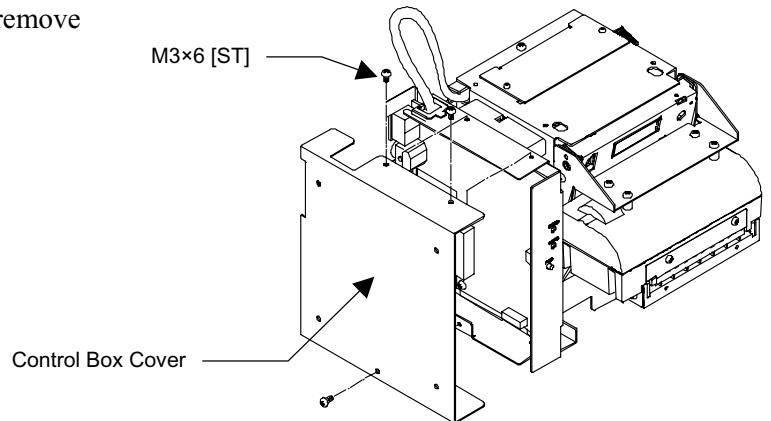

- Remove the two M3×6 (ST) screws and remove the I/F Board.
- Remove the three M3×10 [BT] screws and remove the Control Box.

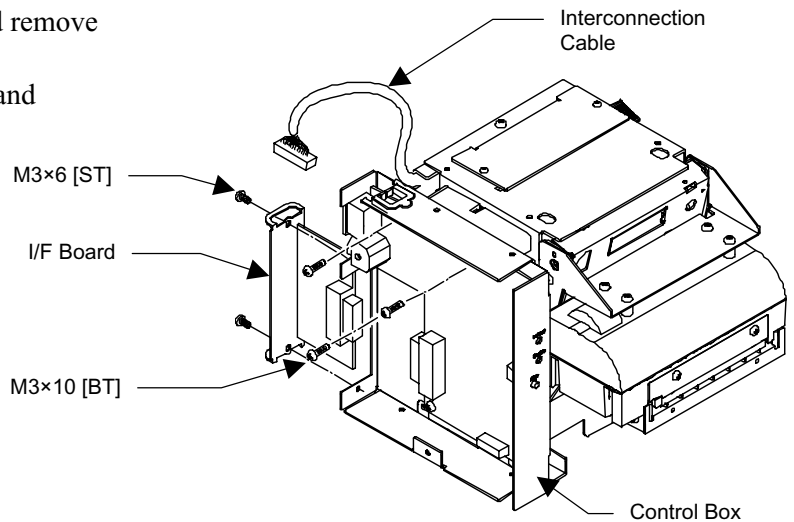

- Remove the three M3×6 (ST) screws and remove the Control Board.

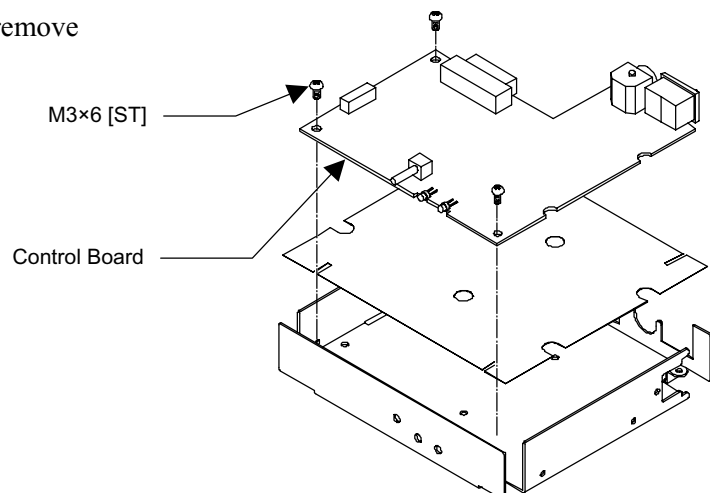

(2) Removing Interconnection Board

- Remove the two M2×3 [ST] screws, pull the Interconnection Board up, and then disconnect the connector.

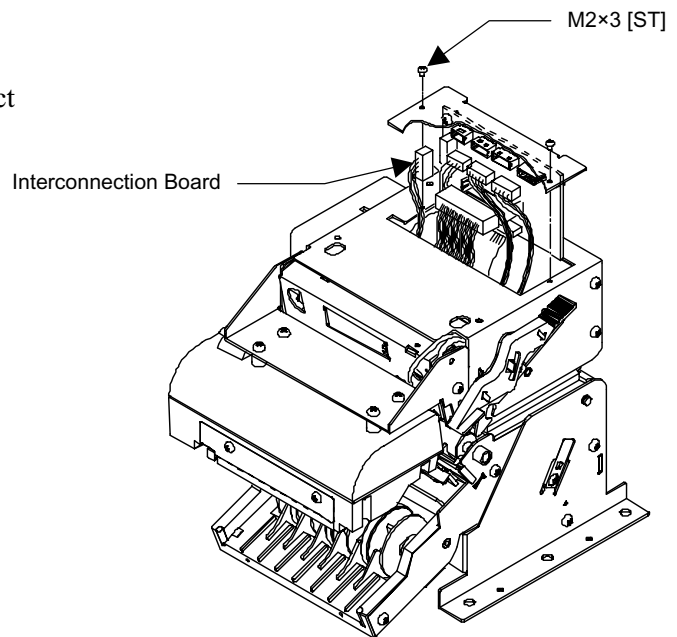

(3) Removing Feeder Unit

- Remove the two M3×6 [ST] screws and remove the Feeder Unit.

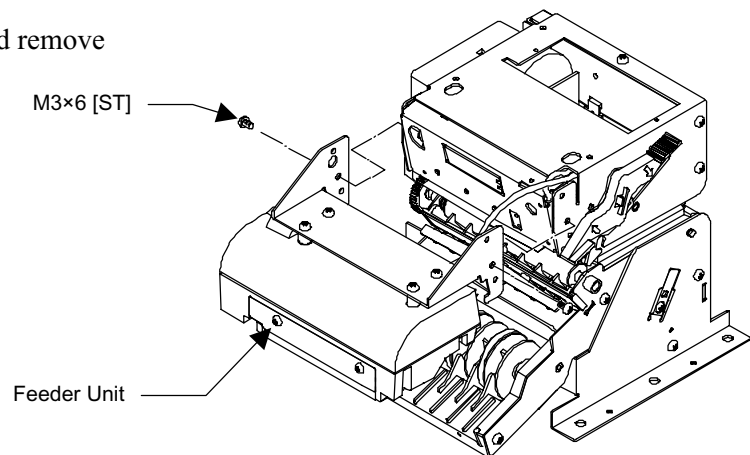

(4) Removing Auto Cutter

- Remove the Auto Cutter fixed at the convexed portion at both sides.

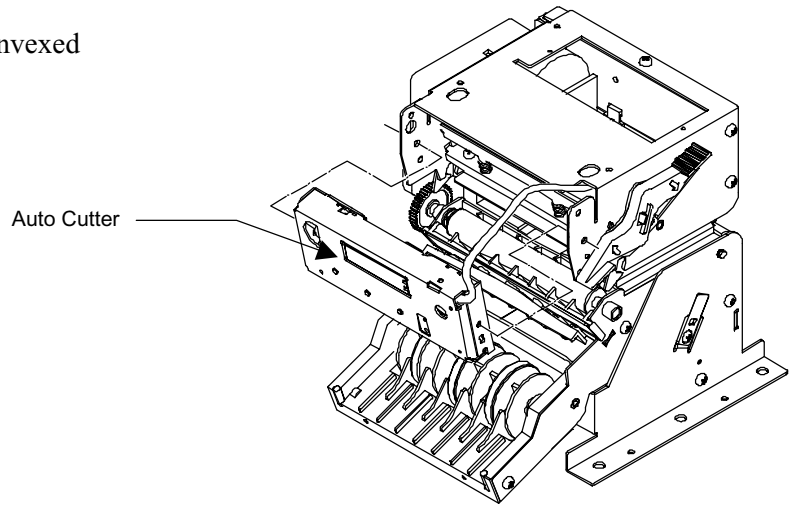

(5) Removing Moving Unit

- Remove the E ring [E-2.5].
- Pull the Shaft out and remove the Moving Unit.

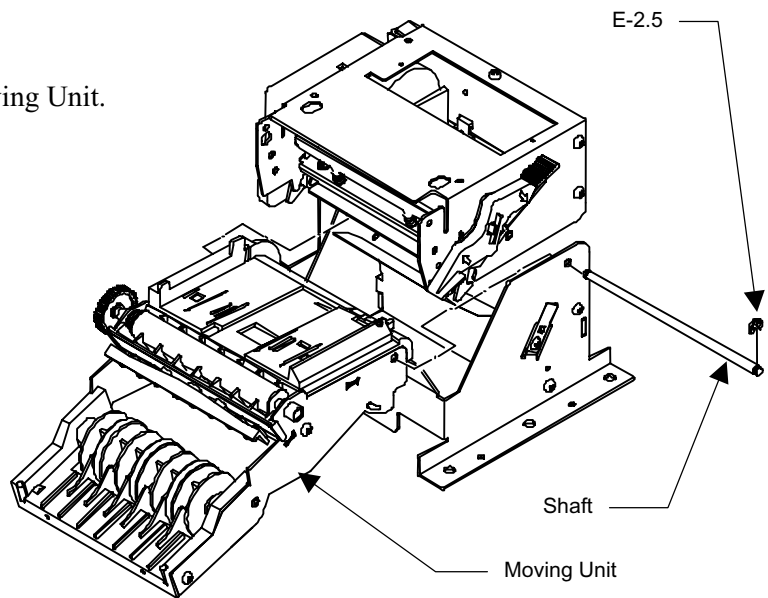

3.2.2 Disassembly of Feeder Unit

- (1) Removing the P-Bracket
 - Remove the M3×6 [BT] screw.
 - Remove the P-Bracket.
- (2) Removing the Upper Cover
 - Remove the four M2.6×8 [BT] screws.
- (3) Removing the Anti-static Brush
 - Remove the four M2.6×8 [BT] screws.
- (4) Removing the Drive Unit
 - Remove the Drive Unit from the Lower Case.

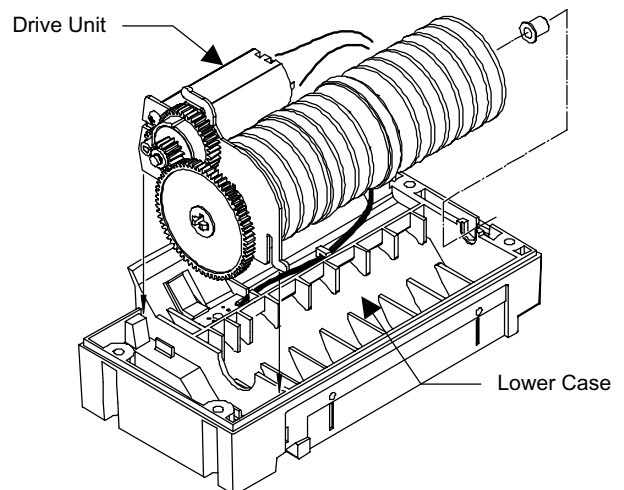
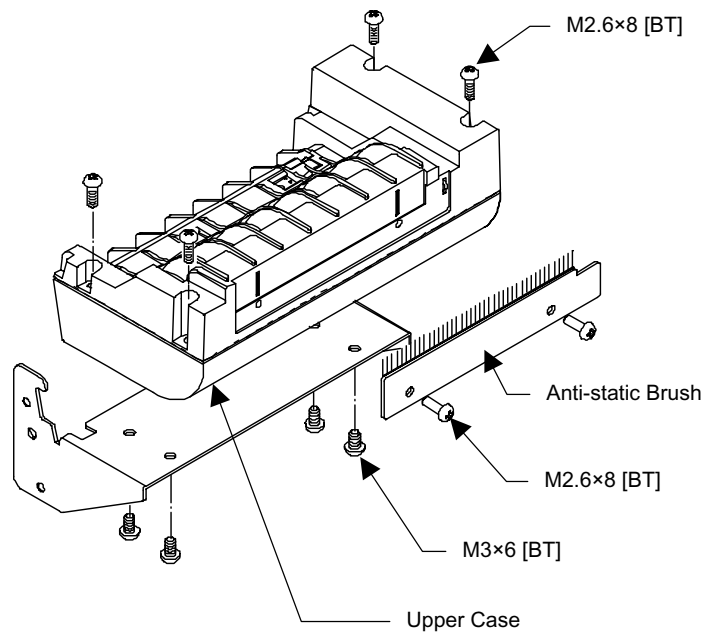

(5) Disassembling the Drive Unit

- Remove the Hook of the Feed Roller and remove the Feed Roller Gear and Bushing.

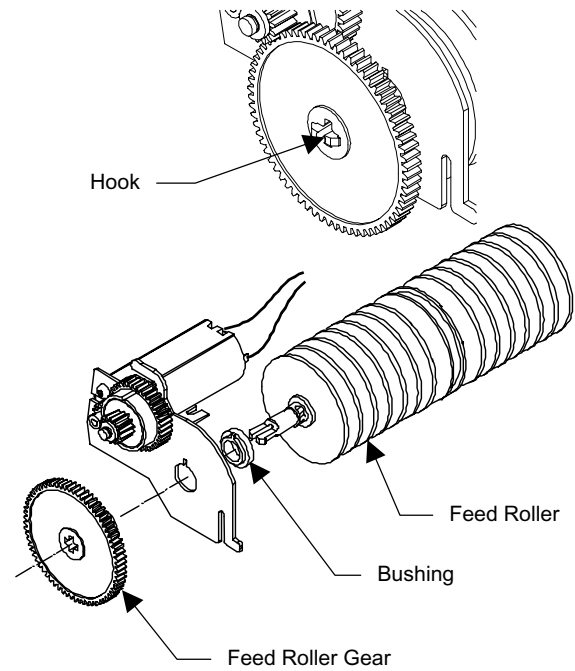

(6) Removing Clutch Assy. and DC Motor

- Remove the E ring (E-2.5) and then remove the Clutch Assy.
- Remove the two M2×3 screws and then remove the DC Motor.
- Remove the Motor Gear from the DC Motor.

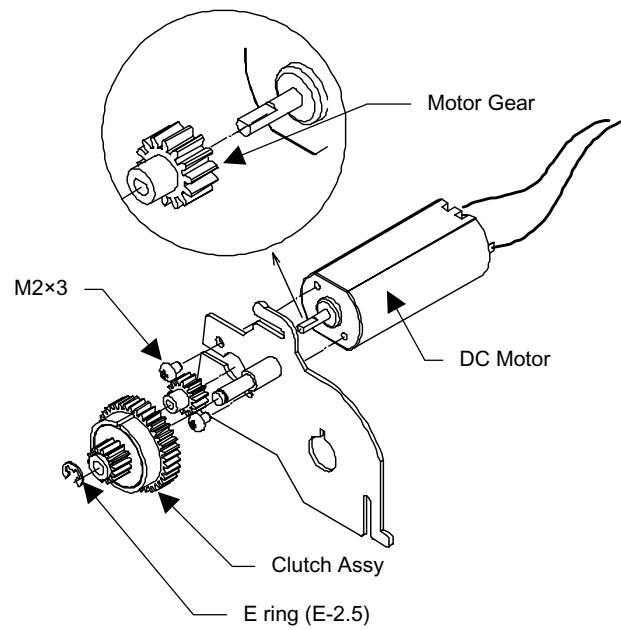

(7) Disassembling Clutch Assy

- Remove the Drive Gear, Slip Gear, and Clutch Spring.

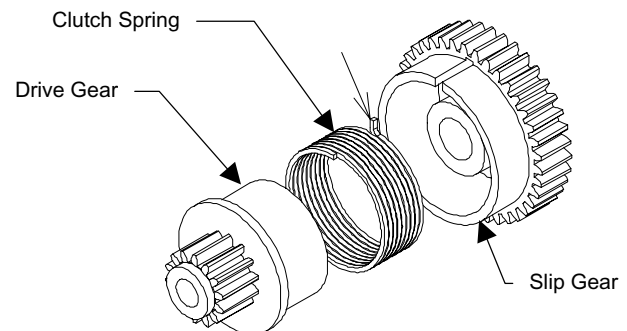

3.2.3 Disassembly of Moving Unit

(1) Removing the Platen Roller

- Remove E-ring (E-4).
- Remove the Platen Gear.
- Remove the two M3×6 [BT] and two M3×6 [ST] screws and then remove the Side Chassis.

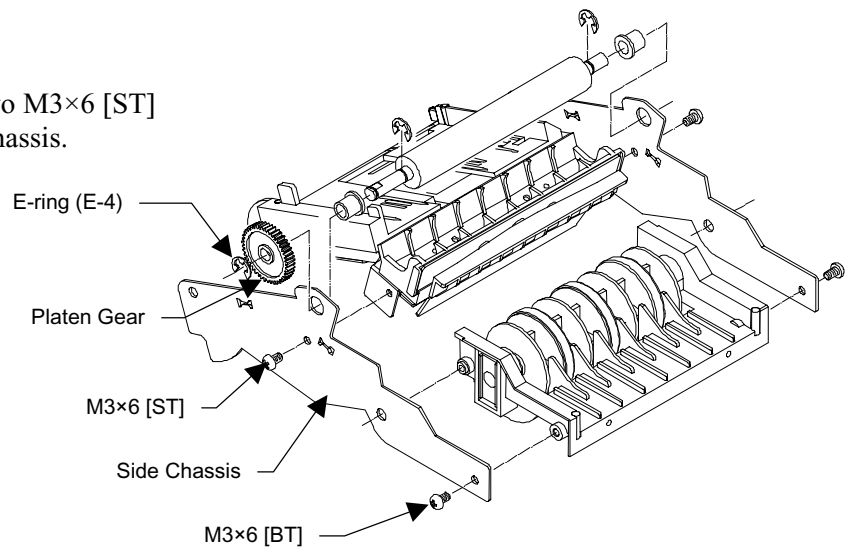

(2) Removing Guide_Assy and Platen BK_Assy

- Remove the four M3×6 [BT] screws.

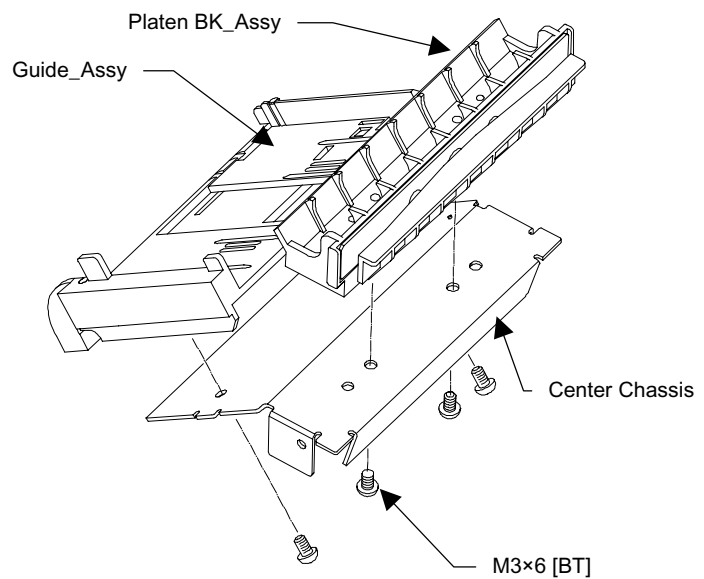

(3) Disassembling Center Guide

- Remove the Slider and Roller-SP and then remove the Feed Roller.

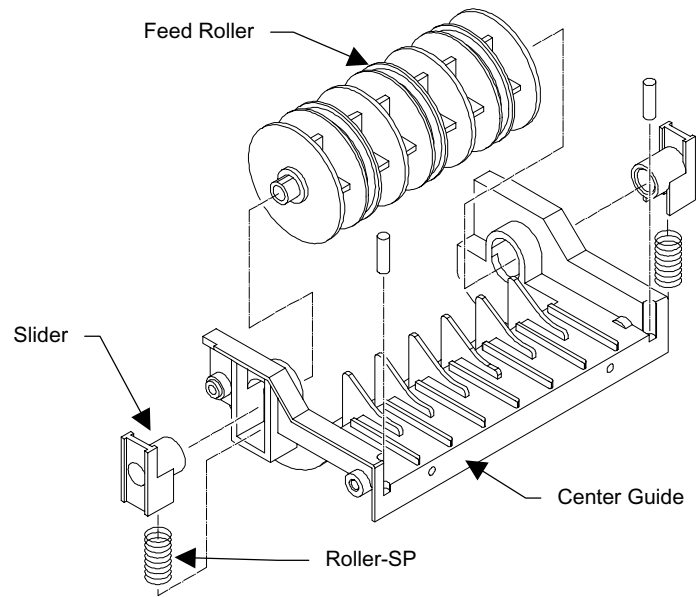

(4) Disassembling Platen BK

- Remove the M2×6 [BT] screw.

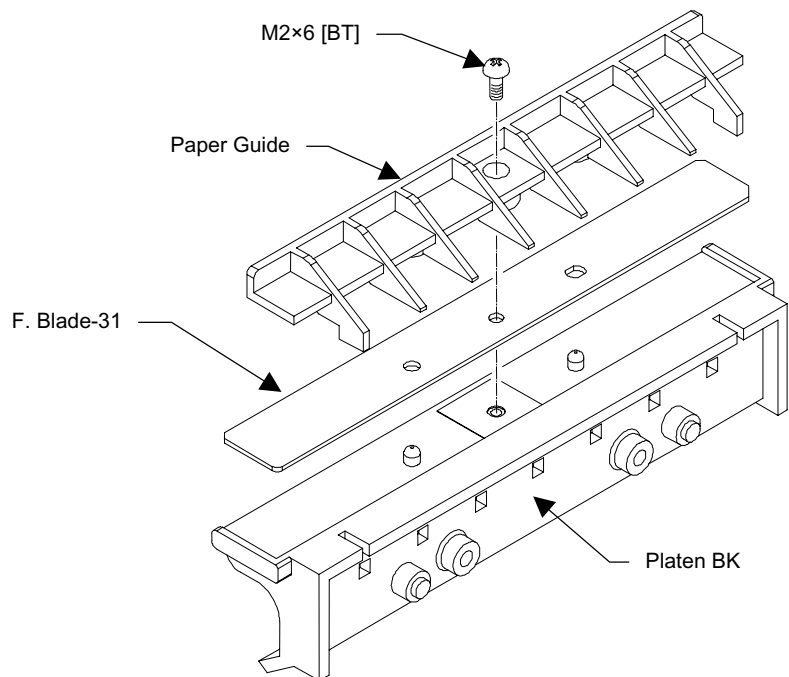

3.2.4 Disassembly of Mechanism

(1) Removing Knob and Hook-R

- Release the hook of the Knob using a flat-head screwdriver.
- Remove Knob, Hook-R, and EXT-SPRING-02.

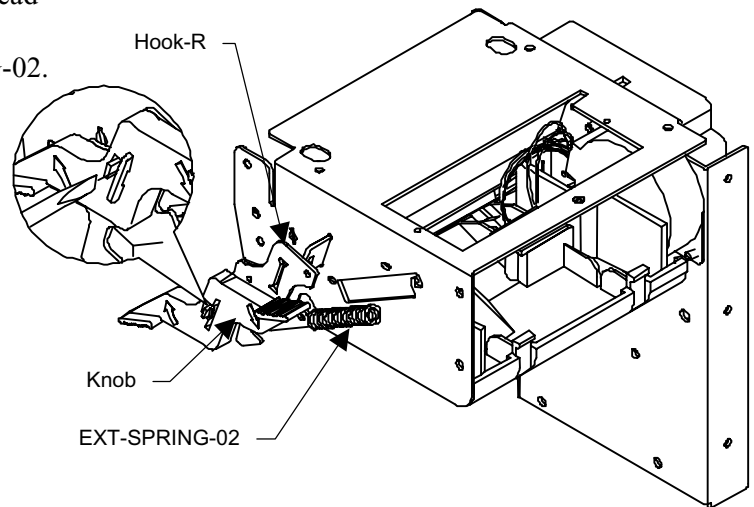

(2) Remove the Upper Guide.

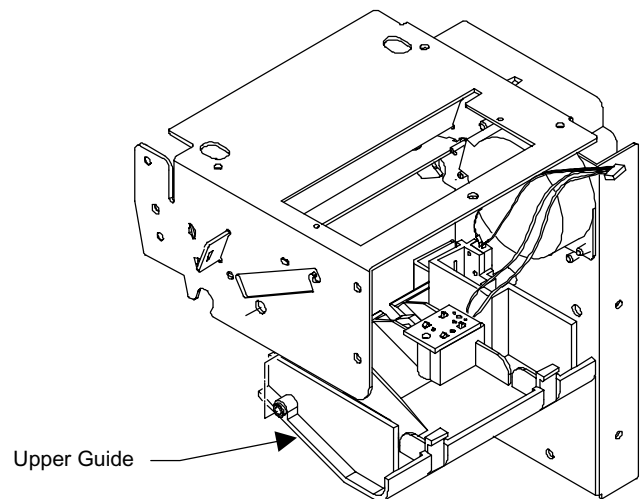

(3) Removing SW_Cable_Assy

- Remove the M2.6×8 [BT] and M1.7×6 [BT] screws.

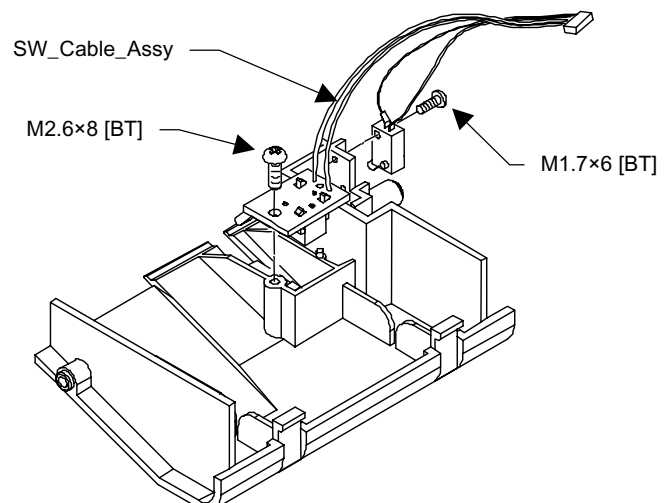

(4) Removing Thermal Head Assy, Head SP, and SP-Holder

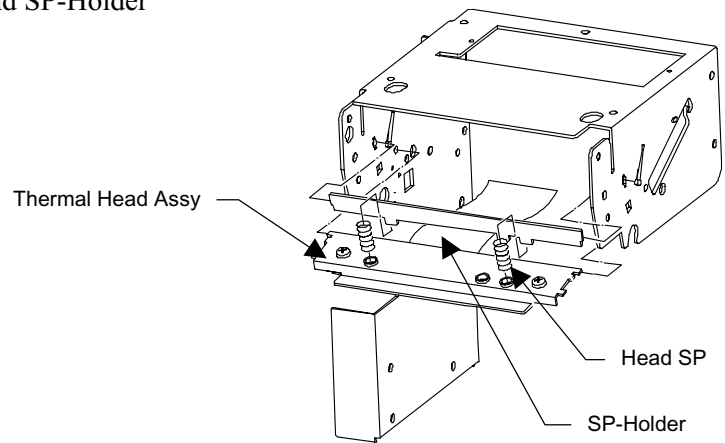

(5) Disassembling Thermal Head Assy

- Remove the M3×4 screw.
- Remove the FFC.

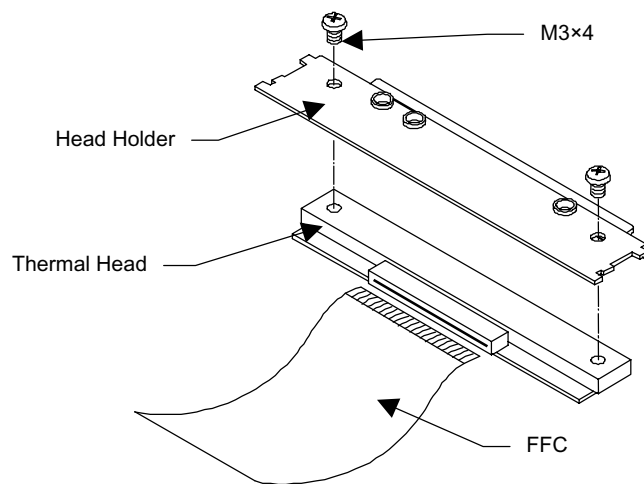

(6) Disassembling Stepping Motor

- Remove the M3×4 screw.

(7) Removing Gear Holder

- Remove the M3×6 [ST] screw.

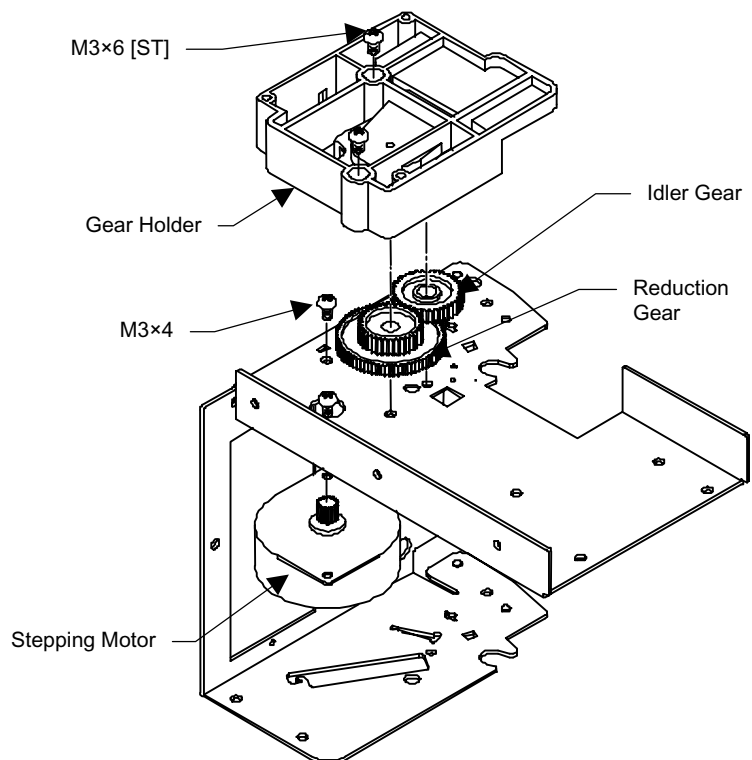

3.3 Reassembly Procedure

Reverse the procedure in “3.2 Disassembly Procedure”.

3.4 Lubrication

(1) Oil (Grease)

Furoyll G-943 (Kanto Kasei Co., Ltd.)

(2) Lubrication points

- ① Gear holder shaft
- ② Platen roller shaft
- ③ Feeder shaft and clutch
- ④ Moving unit roller shaft

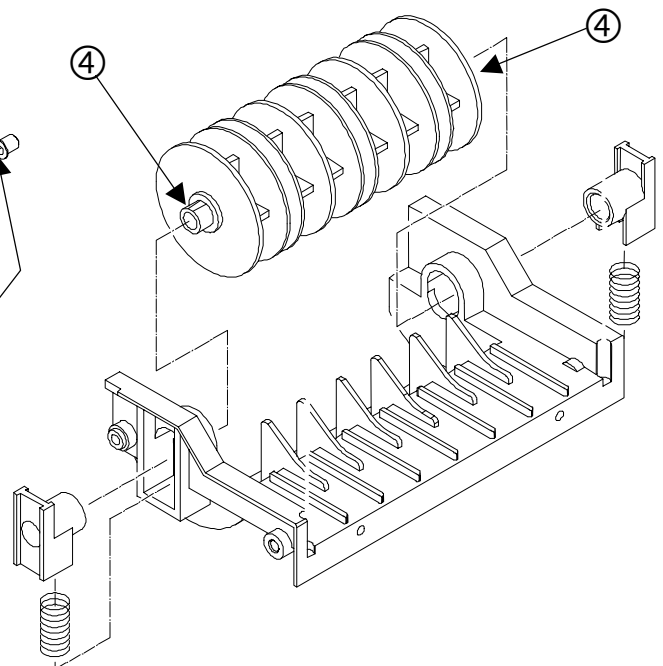
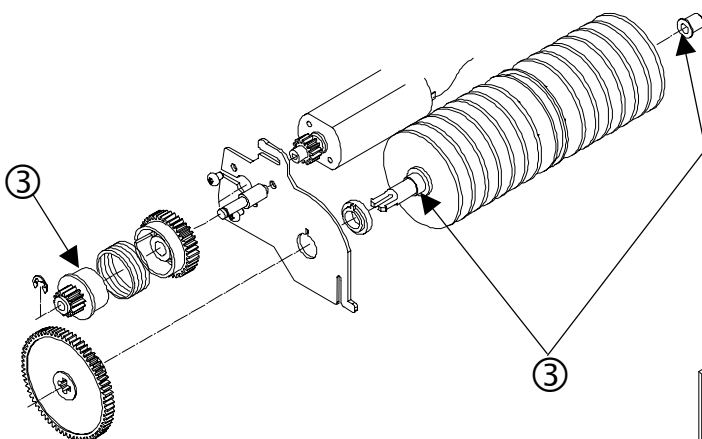
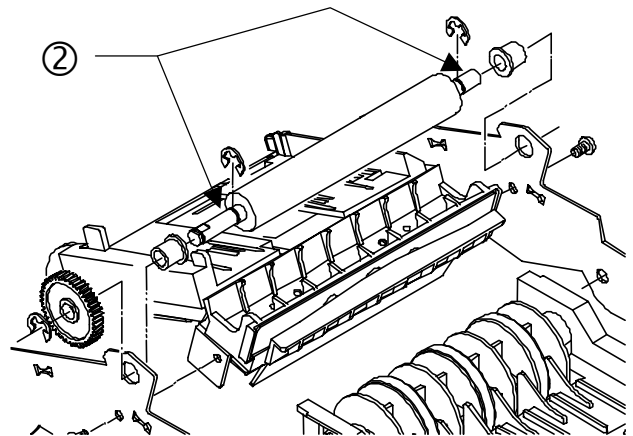
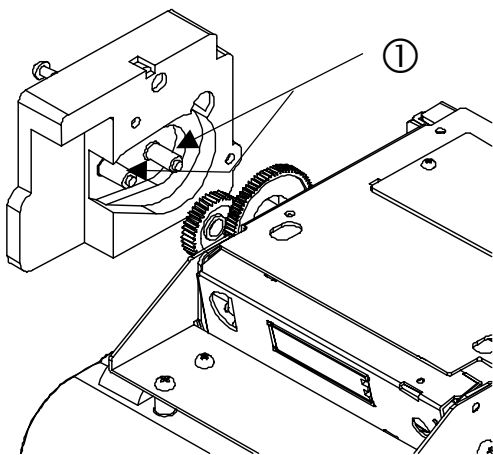

4. TROUBLESHOOTING

4.1 Troubleshooting Procedure

When a trouble occurs, confirm its phenomenon, locate a defective part in accordance with “4.2 Troubleshooting Guide”, and troubleshoot as described below.

Phenomenon	Find a trouble phenomenon in this column. If there are multiple phenomena, take all the corresponding items into consideration. This allows you to specify a hidden defective part.
Cause	Lists as many possible causes as possible. Guess a trouble cause out of them and take its check method to specify the trouble cause.
Check Method	Describes a check method to specify a trouble cause.
Remedy	Troubleshoot by taking a remedy described in this column.

By troubleshooting in accordance with the above-mentioned procedure, you can troubleshoot efficiently with fewer misjudgments.

4.2 Troubleshooting Guide

- Power Supply Failure

Phenomenon	Cause	Check Method	Remedy
No power (POWER lamp not illuminated)	The AC adapter is not connected.	—	Connect the specified AC adapter.
	The fuse is gone.	Check whether any unspecified power has been used so far.	Use the specified AC adapter.
		Check whether the specified fuse is used.	Use the specified fuse.
The fuse immediately goes again after replacing with a new one.	Faulty control PCB assy	—	Replace the control PCB assy.
	The circuit drive power is abnormal.	Check the circuit drive voltage with a DC voltmeter.	Replace the control PCB assy.

* If the fuse is gone with the specified AC adapter used, it is likely that the thermal head unit or control PCB assy is defective. Replace either defective one.
Incidentally, check the wiring of the interface cable.

- **Printing failure**

Phenomenon	Cause	Check Method	Remedy
No printing	Faulty power supply	Check whether the specified AC adapter is used.	Use the specified AC adapter.
	Faulty control PCB assy	—	Replace the control PCB assy.
	Faulty connection of the thermal head connector	Check connection of the thermal head connector.	Connect the thermal head connector properly or replace the head cable assembly.
	Faulty thermal head	—	Replace the thermal head.
Partly not printed	Faulty connection of the thermal head connector	Check connection of the thermal head connector.	Connect the thermal head connector properly or replace the head cable assembly.
	Faulty thermal head	—	Replace the thermal head.
Faint printout or uneven printout	Faulty power supply	Check whether the specified AC adapter is used.	Use the specified AC adapter.
	Low DC output voltage from AC adapter	Check the DC voltage with a DC voltmeter.	Supply the specified AC voltage to the AC adapter.
	Faulty thermal head	—	Replace the thermal head.
	Foreign substance is adhered to the thermal head.	Check whether any foreign substances are adhered to the thermal head.	Dip a cotton swab or soft cloth in ethyl alcohol and wipe the foreign substances with them.
	Non-recommended paper is used.	Check whether the paper being used meets the specification.	Replace it with the specified paper.
	Faulty mounting of the platen roller	Check mounting condition of the platen roller.	Mount the platen roller properly.

- Paper feed failure

Phenomenon	Cause	Check Method	Remedy
Paper is not fed or irregularly fed.	Faulty connection of the motor connector	Check the connecting condition of the motor connector.	Connect the connector correctly.
	Defective motor	Check the DC voltage with a DC voltmeter.	If the supply voltage is normal, replace the motor.
	Faulty power supply	Check whether the specified AC adapter is used.	Use the specified AC adapter.
	Low DC output voltage from AC adapter	Check the DC voltage with a DC voltmeter.	Supply the specified AC voltage to the AC adapter.
	Faulty control PCB assy	—	Replace the control PCB assy.
	Faulty mounting of the platen roller	Check mounting condition of the platen roller.	Mount the platen roller properly.
	Paper feed failure	Check whether or not the paper is jamming or torn and caught in the paper path.	Eliminate unnecessary paper in the paper path and set paper properly.
	Foreign substance in the gear or broken gear	Remove the gear holder and check for any foreign substance caught in the gears or any breakage of the gears.	Eliminate the foreign substance. If the gear is broken, replace it with new one.

- Faulty ejection of paper

Phenomenon	Cause	Check Method	Remedy
Paper is not ejected.	Faulty paper path	Check whether paper remainder is present in the paper path.	Eliminate unnecessary paper.
	Scratch in paper path	Check the paper path for any scratch.	Replace the paper guide.
	Sipping of feed roller	Check whether any foreign substances are adhered to the feed roller.	Dip a cotton swab or soft cloth in ethyl alcohol and wipe the foreign substances with them.
	Poor cutting of auto cutter	Check whether paper is cut correctly. Check the paper path for any paper remainder.	Eliminate unnecessary paper.
	Non-recommended paper is used.	Check whether the paper being used meets the specification.	Replace it with the specified paper.
	Faulty control PCB assy	—	Replace the control PCB assy.
	Faulty power supply	Check whether the specified power supply is used.	Use the specified power supply.
Paper feed roller does not rotate.	Faulty connection of motor connector	Check the connecting condition of the motor connector.	Connect the connector correctly.
	Defective motor	Check the DC voltage with a DC voltmeter.	If the supply voltage is normal, replace the motor.
	Faulty power supply	Check whether the specified power supply is used.	Use the specified power supply.
	Foreign substance in the gear or broken gear	Check for any foreign substance caught in the motor gear and feed roller or any breakage of the gears.	Eliminate the foreign substance. If the gear is broken, replace it with new one.

- **Faulty sensor**

Phenomenon	Cause	Check Method	Remedy
Does not detect presence of paper. Does not detect paper near-end status.	Faulty paper sensor	Check whether the ERROR lamp flickers when paper is out.	Replace the sensor PCB assy.
	Faulty paper near-end sensor		Remove the paper near-end sensor assy.
	Foreign substance is attached to the paper sensor	Check whether any foreign substances are adhered to the paper sensor.	Remove the foreign substance.
	Faulty connection of the paper sensor connector	Check the connecting condition of the paper sensor connector.	Connect the connector correctly.

- **Faulty auto cutter**

Phenomenon	Cause	Check Method	Remedy
The cutter does not function.	Faulty connection of the auto cutter connector	Check the connecting condition of the auto cutter connector.	Connect the connector correctly.
	Faulty power supply	Check whether the specified AC adapter is used.	Use the specified AC adapter.
	Defective auto cutter	Check the DC voltage with a DC voltmeter.	If the supply voltage is normal, replace the auto cutter.
	Paper feed failure	Check whether or not the paper is jamming or torn and caught in the paper path.	Eliminate unnecessary paper in the paper path and set paper properly.

5.2 Exploded View of Mechanism

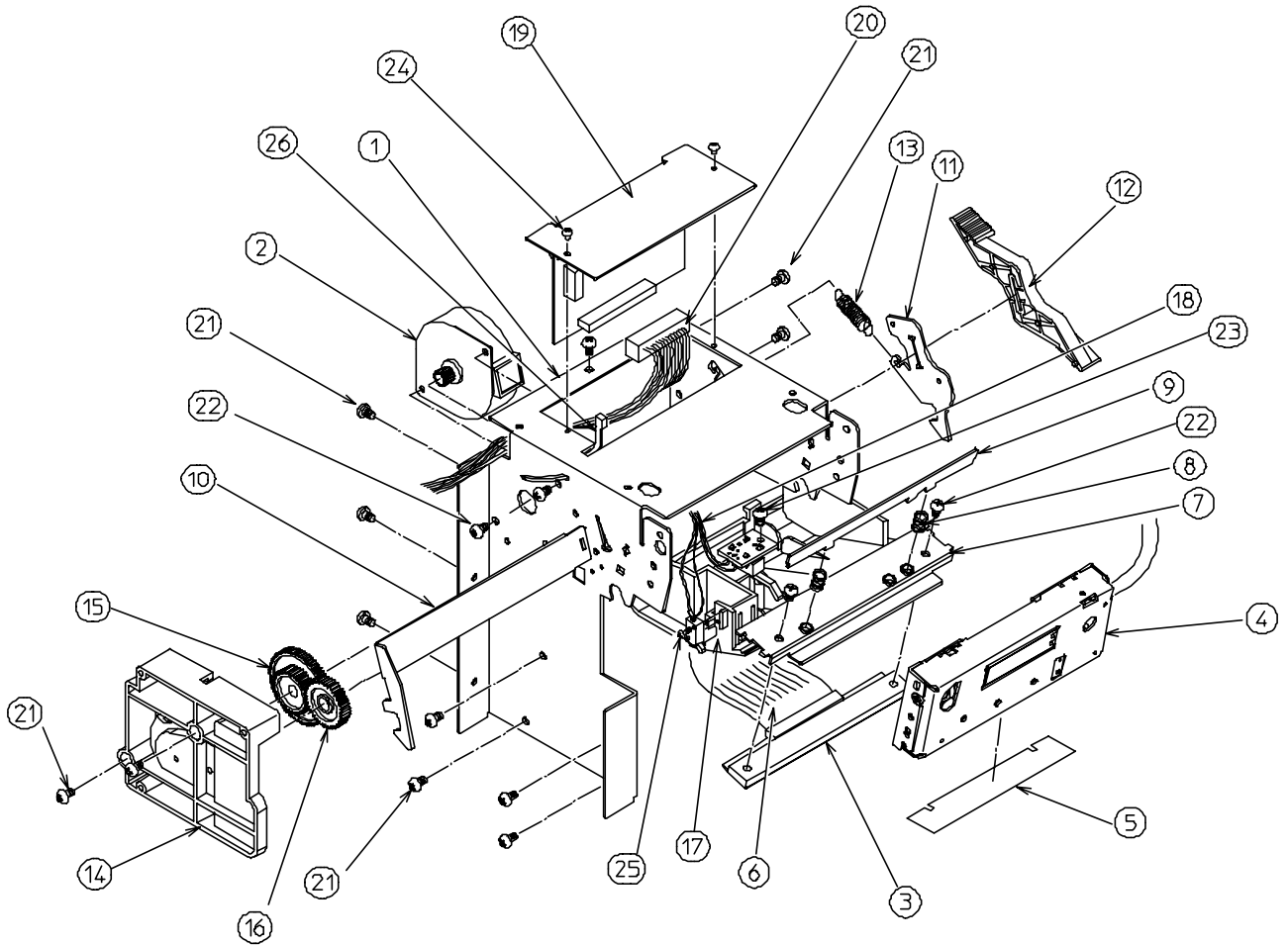

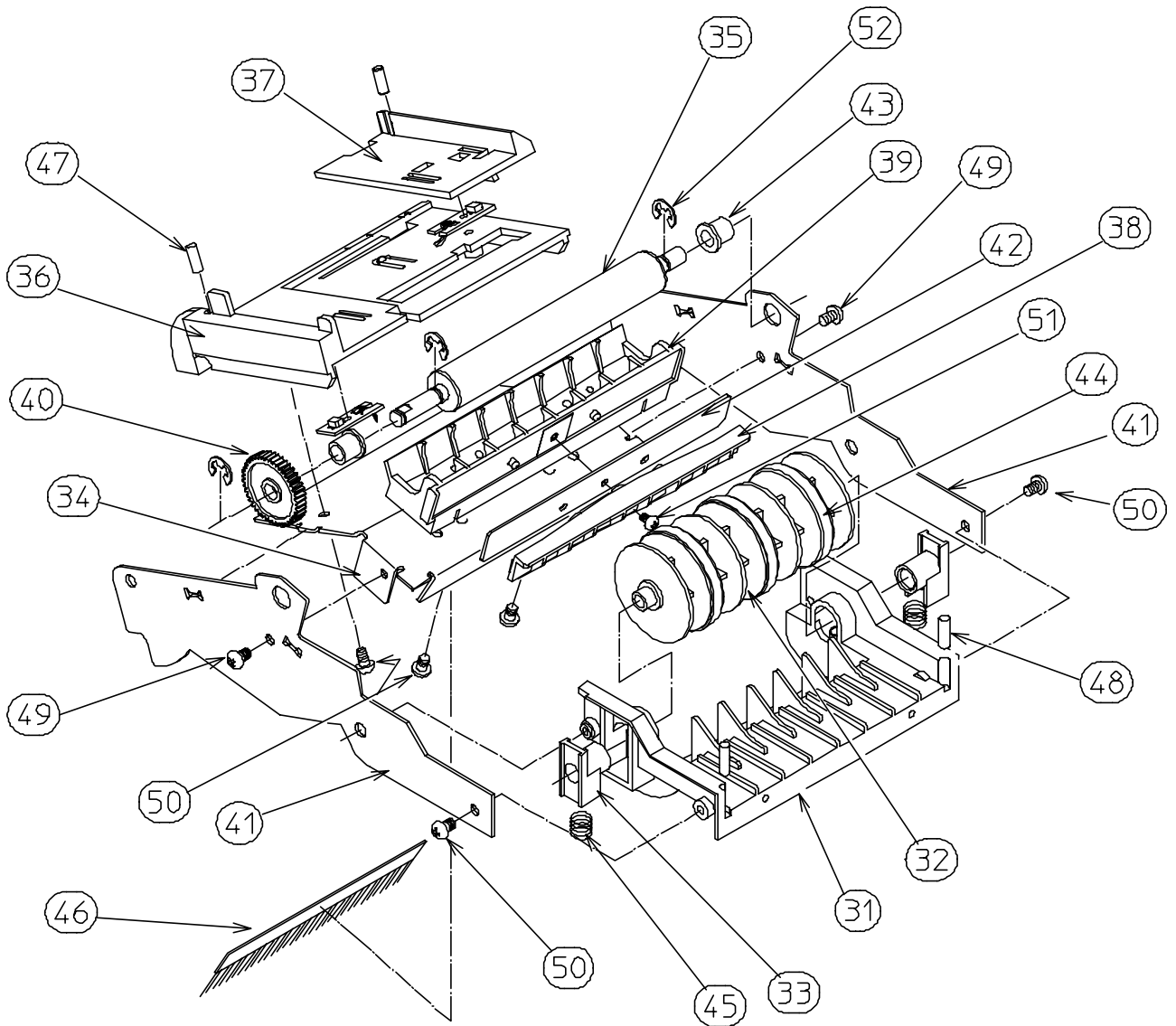

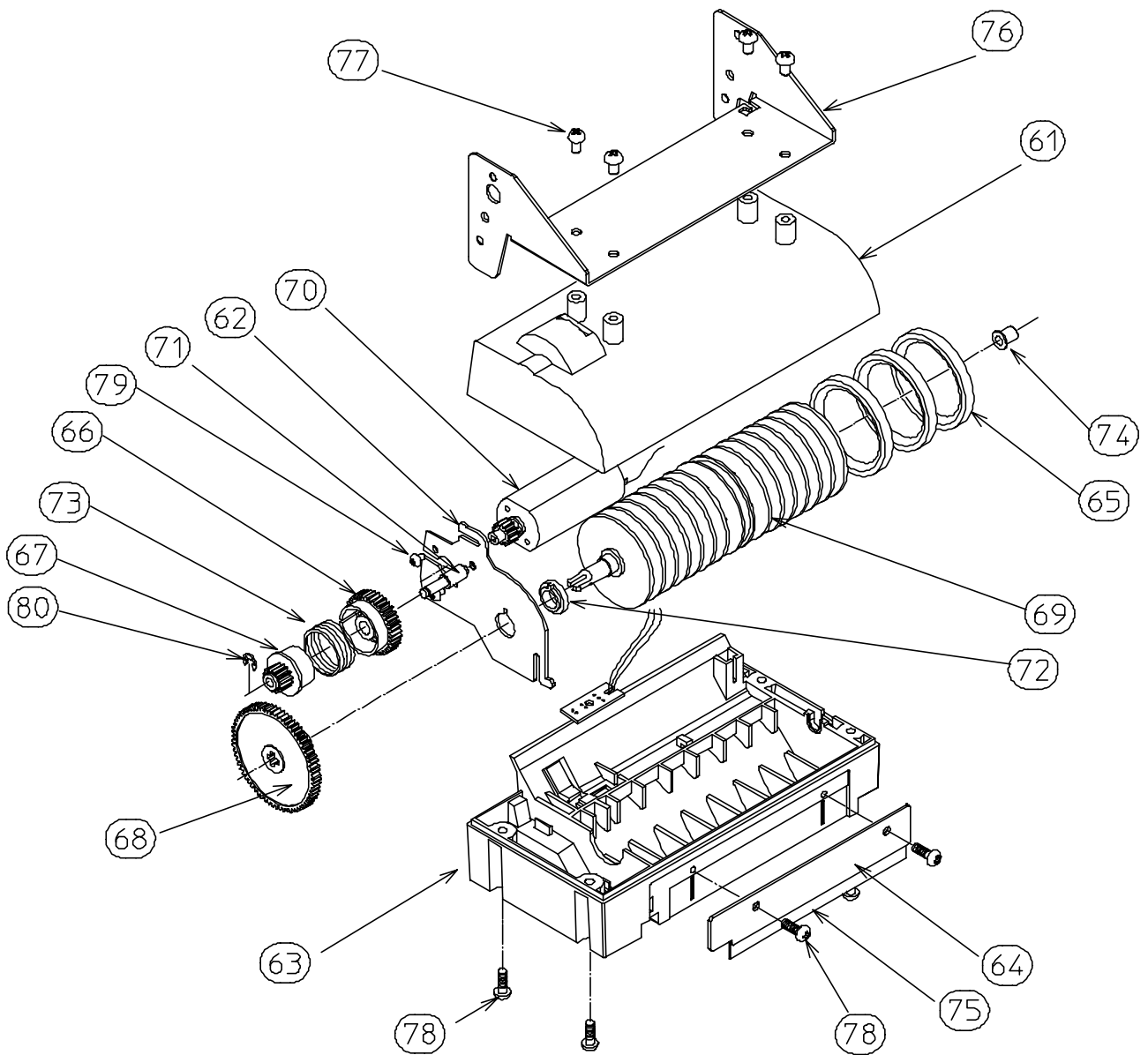

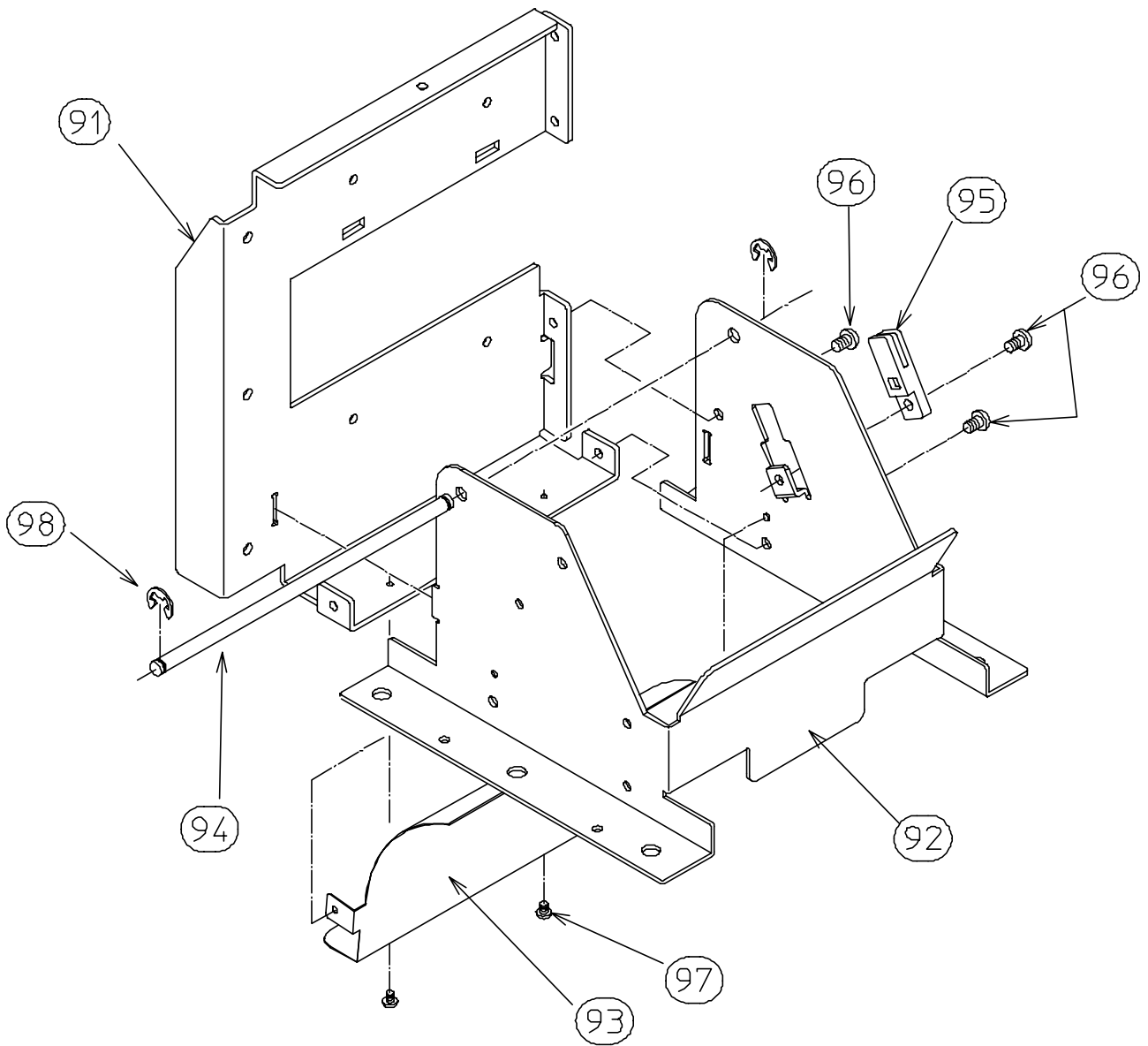

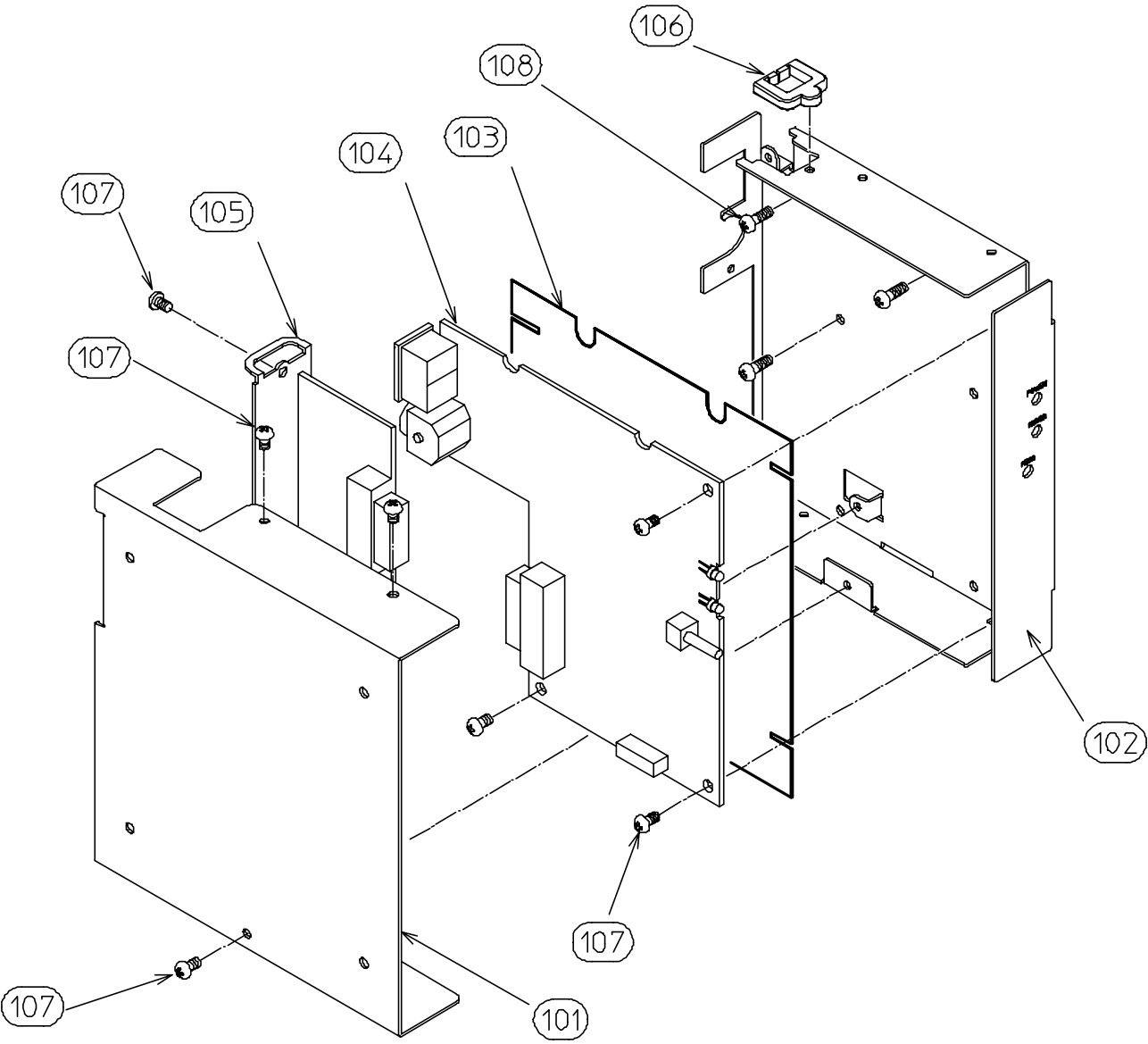

6. CIRCUIT DIAGRAM

6.1 Main Board

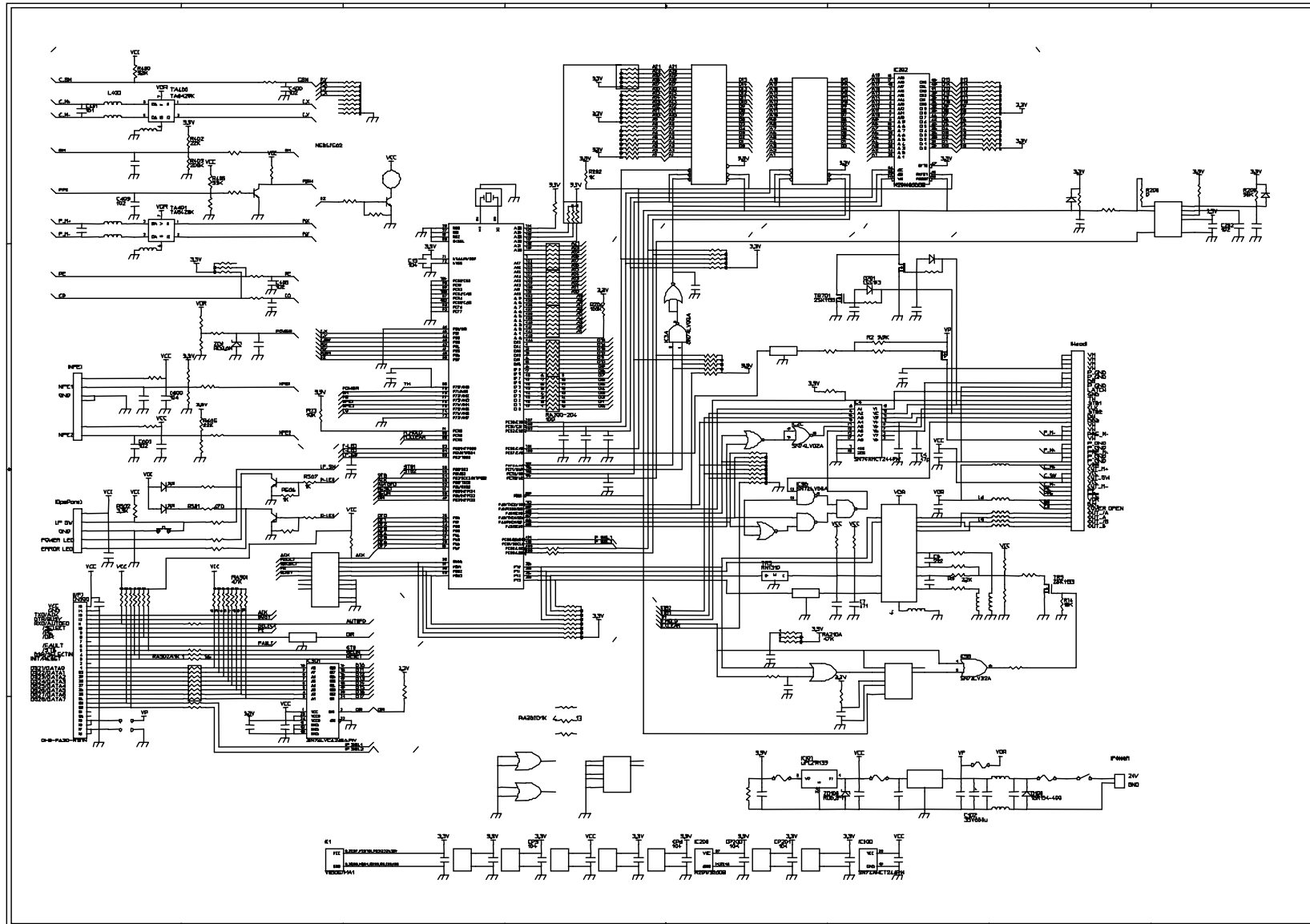

6.2 Interconnecting Board

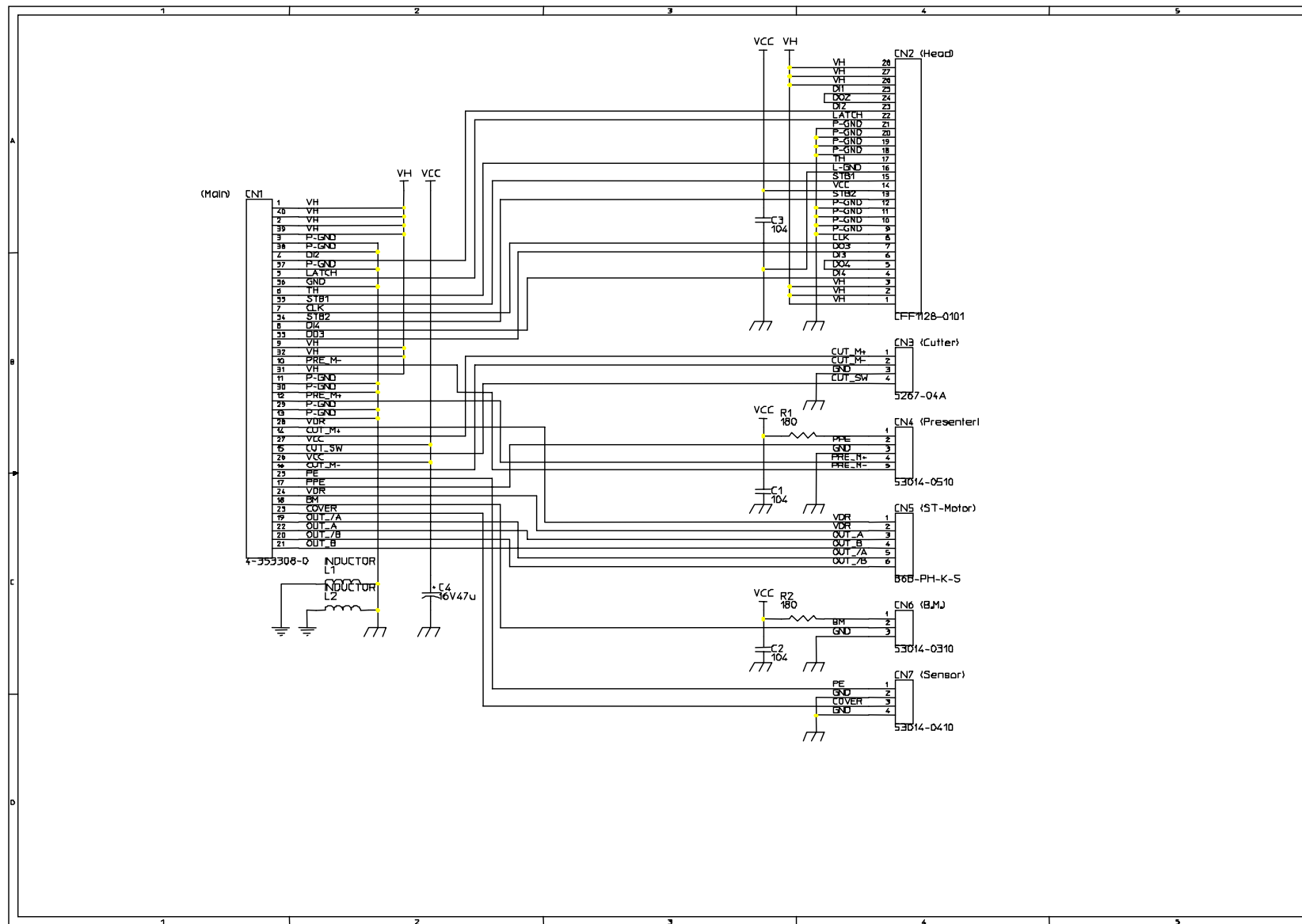

6.3 Serial Interface

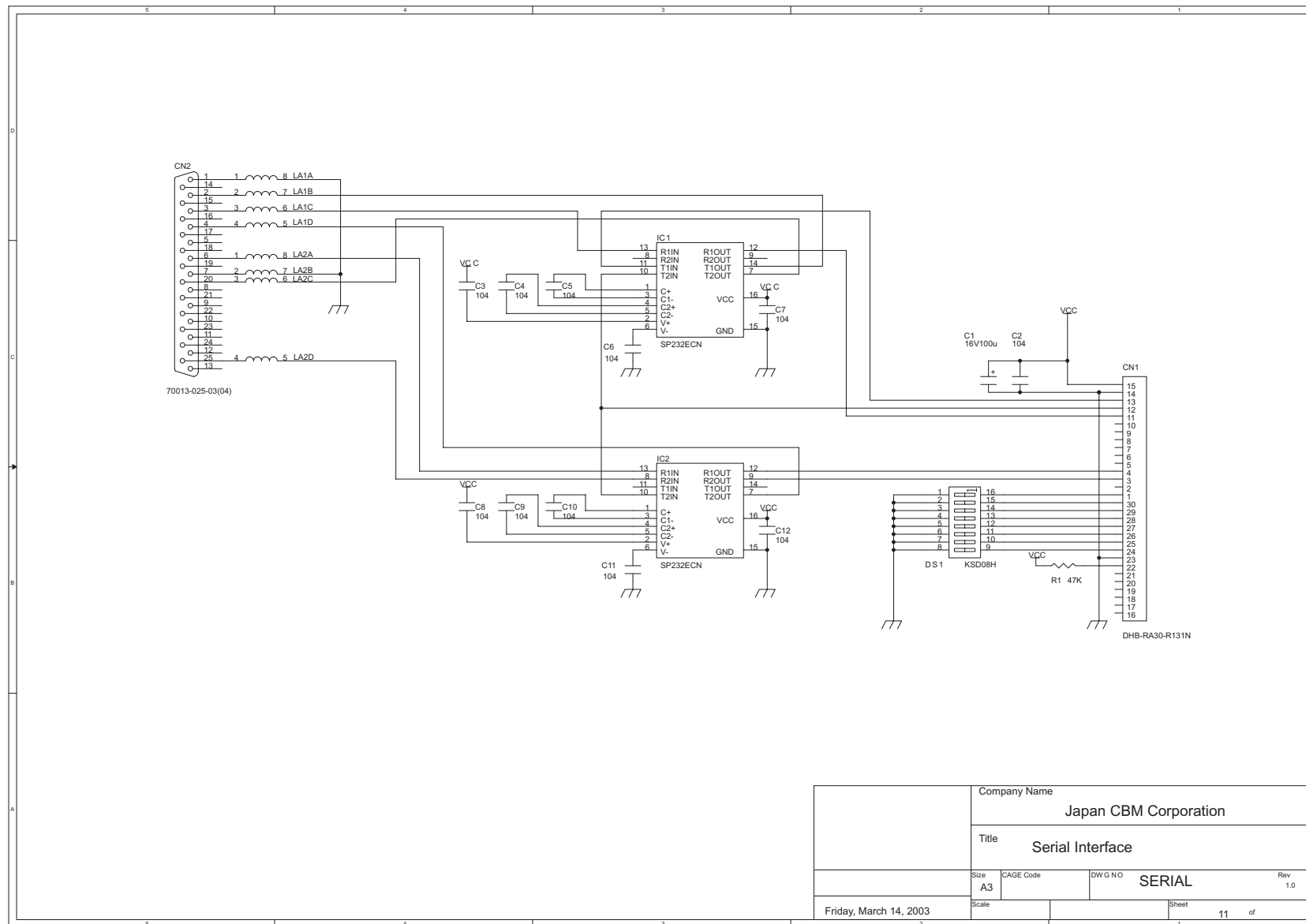

Company Name		Japan CBM Corporation	
Title		Serial Interface	
Size	CAGE Code	DWG NO	Rev
A3		SERIAL	1.0
Friday, March 14, 2003		Scale	Sheet 11 of

6.4 Parallel Interface

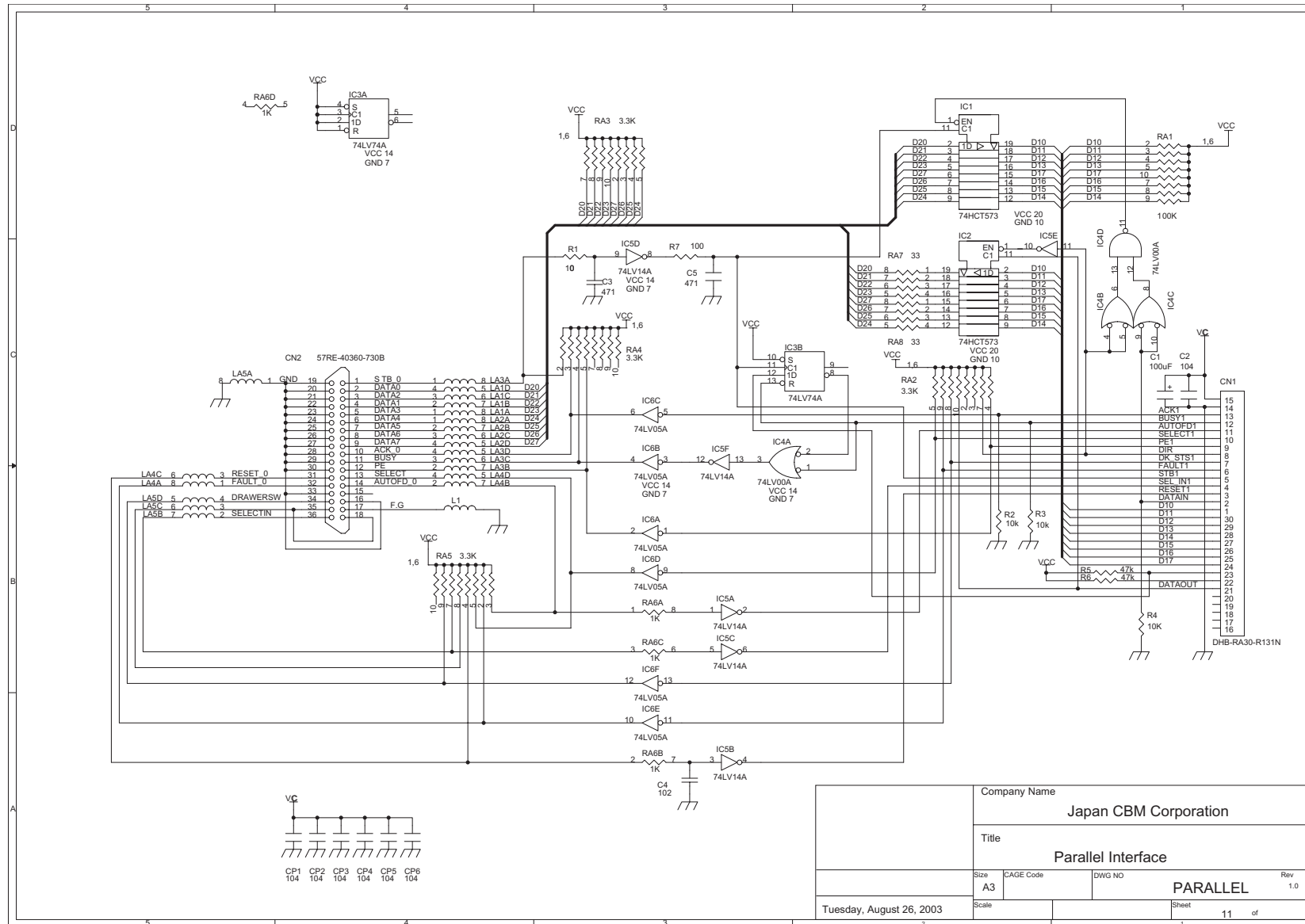

Company Name			
Japan CBM Corporation			
Title			
Parallel Interface			
Size	CAGE Code	DWG NO	Rev
A3			PARALLEL 1.0
Tuesday, August 26, 2003		Scale	Sheet 11 of

7. EXTERNAL VIEW

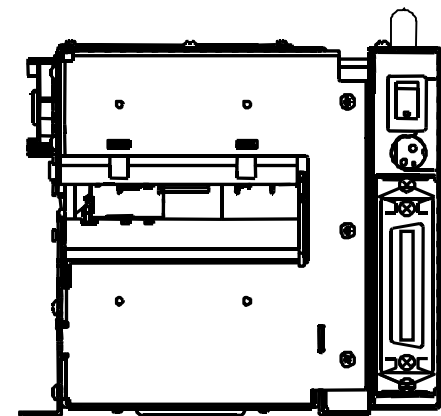
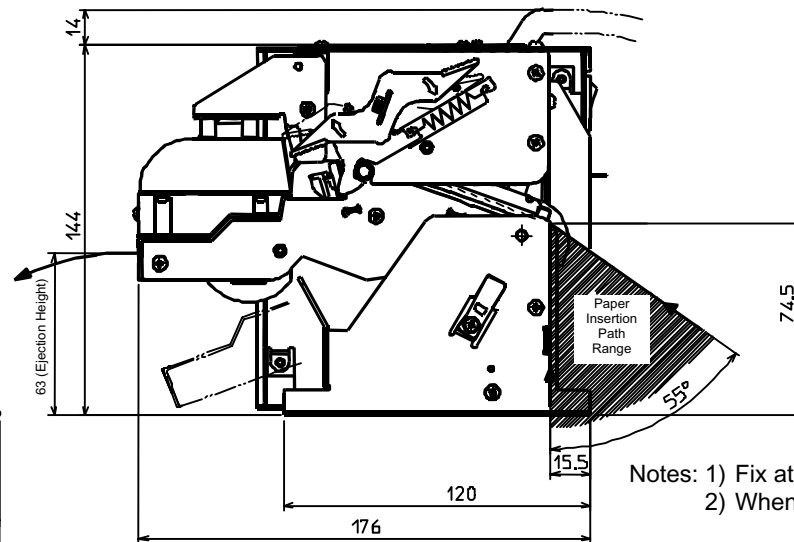
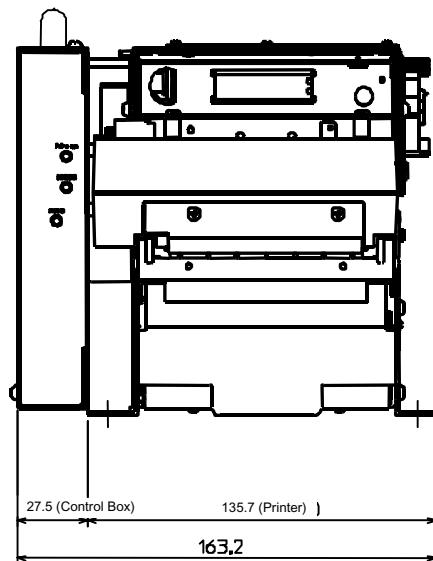
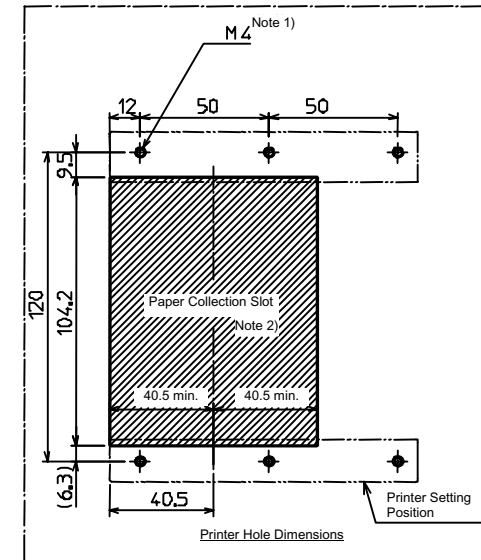
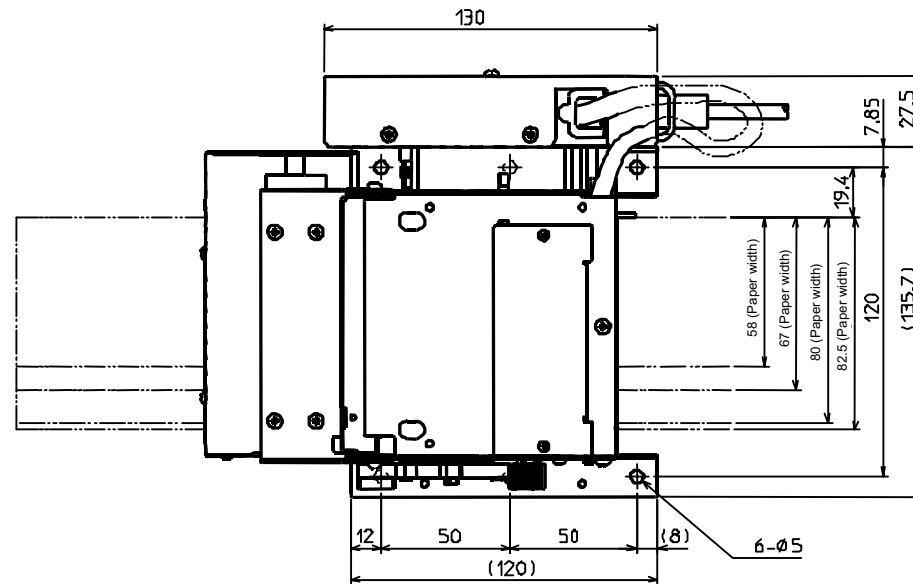

- Notes: 1) Fix at 2 places or more in one side totaling 4 places or more.
 2) When collecting paper, be sure to prepare a paper collection hole.